

User Notes

FOCAL SPOT ANALYZER - HIGH POWER (FSA- HP)

CAMERA MODEL SP932U

P/N SP90603



DIMENSIONS

FSA-HP with SP932U Camera

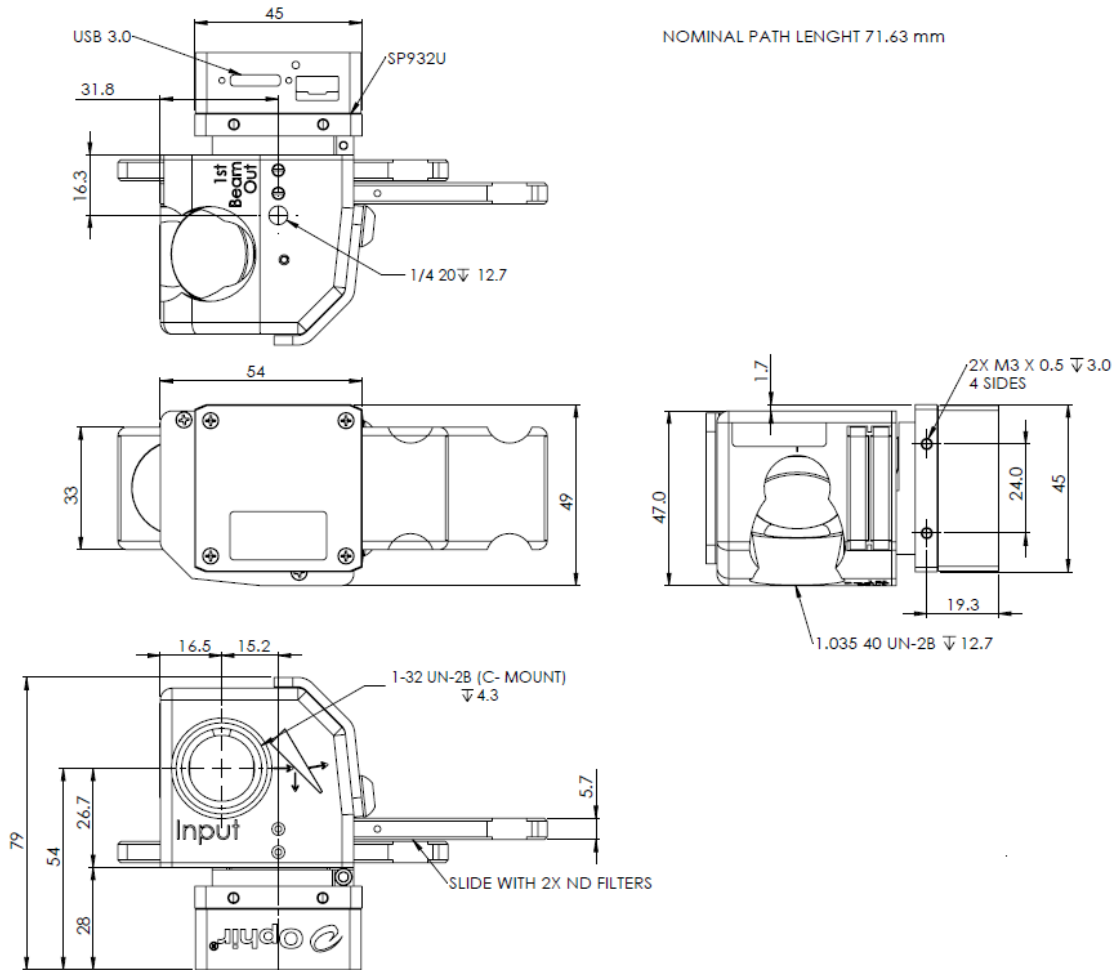

INTRODUCTION

The Focal Spot Analyzer for High Power lasers allows measuring NIR (~1064nm) focused or collimated laser beams profiles up to **5kW** or **15MW/cm²** and calculating the focal spot position with **50 μm** accuracy.

A fraction of the incoming beam is reflected through the front surfaces of a pair of orthogonally oriented wedges. Less than 0.0001% (1/10⁶) of the beam is reflected towards Ophir Beam Profiler Camera and less than 0.1 % towards optional Ophir power meter while remaining 99.9% of incident laser beam is transmitted. Thereby enabling beam shape, focal spot, beam waist and overall power measurement of up to 5kW or 15MW/cm² high power laser.

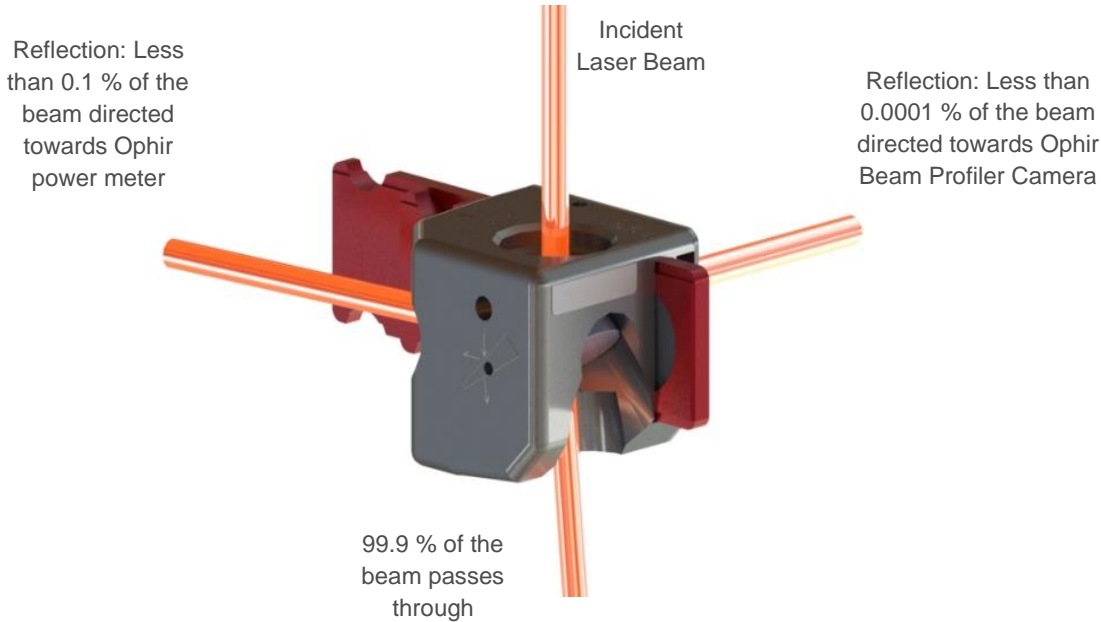

Each direction provides uniform attenuation of any beam shape: gaussian, flat-top, doughnut shape while preserves the polarization and overall profile of the incoming laser beam thus providing accurate sample of incident beam.

50µm accurate Factory calculated optical path between the top surface of the FSA and the camera CMOS sensor, allows measuring exact focal spot location. A set of 6 interchangeable ND filters is provided to make final intensity adjustments to the beam before it reaches the camera imager. The exact optical path extension by ND filters is calibrated and described in section **Optical Path Calculation**.

The FSA-HP housing has multiple mounting points for easy and versatile installation variations, C-mount stackable design compatible with other C-mount accessories.

Warning : when operating with high power lasers

Read the User Notes carefully to avoid damaging FSA-HP.

Avoid any contact with quartz wedges in order not to damage the surface. In case of wedge contamination, please read cleaning instructions and do not attempt to wipe the wedges.

In case the quartz wedge was damaged, please contact Ophir for further decision regarding cleaning or replacing the wedge.

When operating, always start lasing at low intensity and verify correct position of the focal spot, usually on Beam Profiler Sensor and only after that, increase the laser power.

FSA-HP is designated to focus the laser on the camera sensor plane and not the wedge surface. It is not recommended to focus the laser on the wedges as the intensity of very small spots might damage the quartz wedge.

FACTORY CALIBRATION

Focal Spot Analyzer is pre-calibrated in the factory with 50µm accuracy between the top surface (datum) and the camera sensor. A detailed explanation about optical path length measurement is provided in section **Optical path calculation**

The camera orientation can be easily rotated to fit the needs of your beam.

1. Use the provided hex key to loosen the screw securing the camera.
2. Rotate the camera as needed.
3. Make sure that the camera is flush with the beam splitter housing before tightening the screw to maintain the calibration distance.
4. Re-secure the screw to tighten the camera in place.

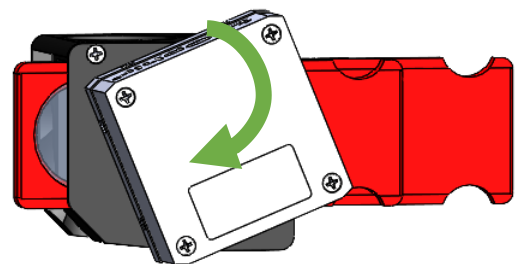
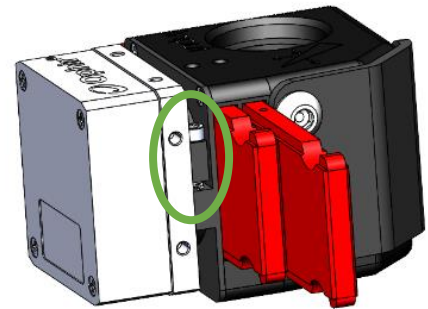

Warning: Do not remove the ring from the camera. Doing so will interfere with the calibration of the system.

Note: We do not recommend removing the camera when rotating. There is no window protecting the camera sensor and removing it will make it more susceptible to damage or dust contamination

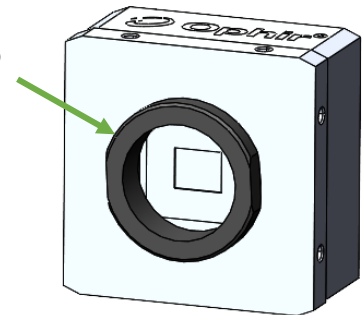

OPTICAL PATH CALCULATION

With the beam traveling through the ND filters, there is an inherent offset that occurs. This offset must be considered when determining the actual beam path distance.

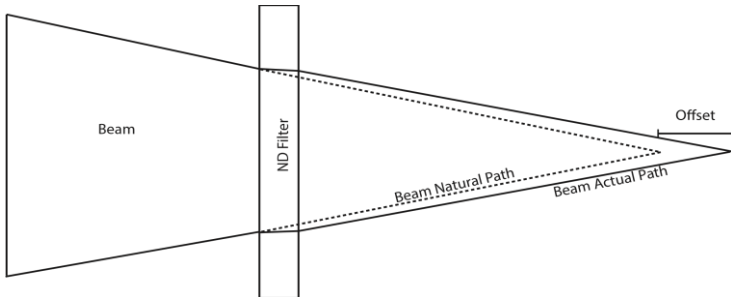

Each beam splitter housing and ND Filter holder has its own calibrated dimensions printed and placed on the unit. To calculate the total path length, we need to look at all the variables.

Total path length = [calibrated path] + [Filter offset_a] + [Filter offset_b]

Note:The calibrated path is the internal distance from the top surface (Datum reference) of the FSA-HP to the camera sensor and is found on the label with the serial number.

The total path length then needs to be added to the distance the beam travels from the source where it enters the FSA-HP to give the actual travel length of the beam.

Example:

In this example we are using FSA-HP with ND 3.0 and 0.8 for attenuation. To fill out the equation we will need to look at the Path Length Offset found on the labels for ND filter 3.0 and ND filter 0.8 as shown below.



Our equation becomes:

Total path length = 72.32mm + 0.64mm + 0.76mm = 73.72mm

INSTALLATION AND SETUP

1. The FSA contains of beam splitter attached to the camera as shown above. Camera can be rotated at any required orientation as described in **Factory Calibration**.
2. Position the FSA so the laser beam enters the center of the input port at a 90° incidence.
3. Removable beam blocker. The beam blocker is designated to keep the wedge surface protected during handling operation. It can be left attached or removed, to have additional beam sampling for power measurement. The resulting beam intensity is estimated ~0.1% of incident beam power/ energy. That beam could be used for simultaneous measurement of laser power via Ophir Power Meter.

A 1.035-40 thread is provided behind each wedge along the axis of the output beam that can be used to directly mount accessories with 1" lens tubes such as beam dumps or even power and energy sensors to the FSA.

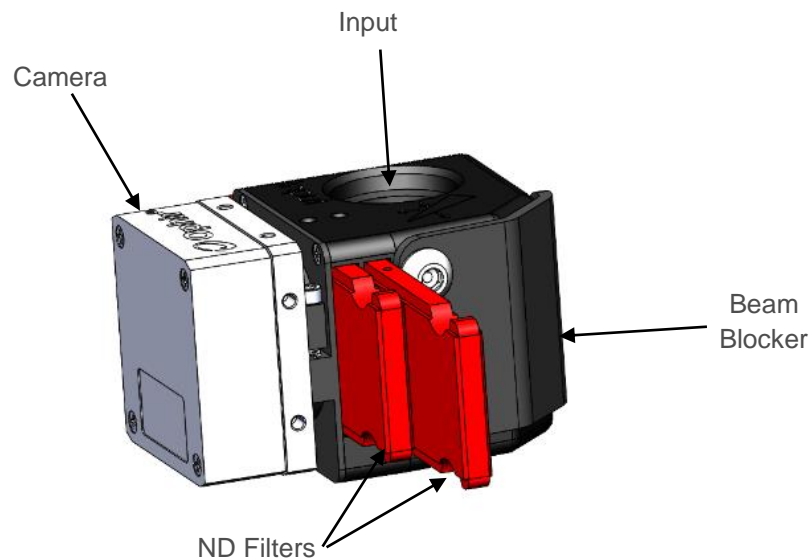

4. The main beam will exit the FSA turned approximately 6 degrees as demonstrated. Provision must be made to safely contain the transmitted beam. An optional beam dump or power meter is available to contain the beam if required.

Beam reflection may change at different incidence angles or position offsets. Therefore, it's recommended to set the FSA-HP so that the laser beam (or red alignment beam) enters the center of the input port at a 90° incidence.

Warning: You must provide a beam stop for the laser beam that passes through the beam sampler. The beam stop must be able to withstand the continuous power/energy of the input beam.

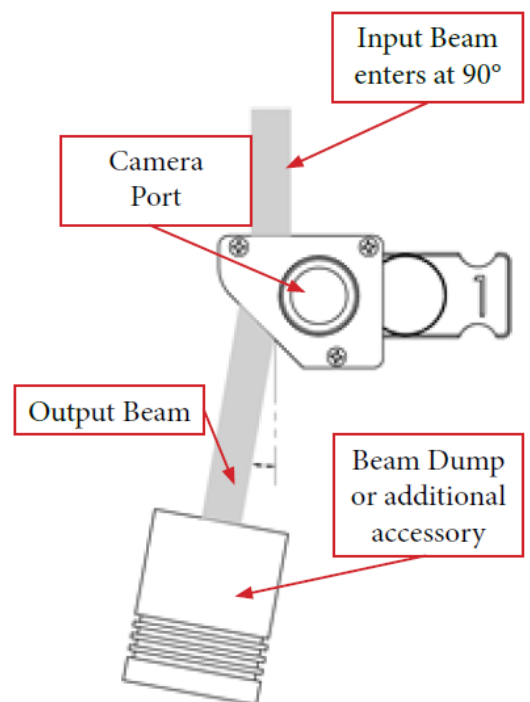

OPERATION

1. Start the beam profiler software and adjust the ND filter holders until the maximum beam intensity is approximately 80% of saturation. See **Appendix A** for ND filter details.

If there are interference effects seen, slight angling of the setup to the beam path may eliminate this.

2. If no picture is seen, check again that the beam is aligned into the sampler. If the image is saturated when the maximum ND filters are in place, lower the camera signal below saturation by reducing the camera exposure setting.

Note: ND filters may start to thermal lens and deform the observed beam profile above 5W/cm² for beam size 5mm, 10W/cm² for 2mm beam and >30W/cm² for 1mm beam.

Caution: The damage threshold for the ND filters is 50 Watts/cm². Make sure the power density in the beam as it hits the ND filters does not exceed this amount. If the beam is converging (focusing) rather than collimated, be sure to take this effect into consideration as well.

3. During high power laser emission, due to extremely high beam attenuation, scattered NIR light could interfere with the beam measurement by increasing background. To reduce the scattered light effect, distance the beam dump from the FSA-HP assembly and using beam dump models designated to reduce NIR scattering.

PRODUCT INFORMATION

Model	FSA-HP-NIR-SP932U
Part No.	SP90603
Wavelength ⁽¹⁾	1000-1100nm
Wedge Material	UVFS
Wedge Reflection	<0.1%
Surface Quality	λ/6
Clear Aperture	15mm
FSA-HP Reflection	0.000025% - 0.0001% (1/10 ⁶)
Wedge ND value	≥3
Maximum Laser Power Exposure	5 kW for up to 10 minutes
Minimum Detectable Laser Power	100 mW
Maximum Power Density ⁽²⁾ , Energy Density	15MW/cm ² , 10J/cm ² at beam splitter
3 x Bulk Filters ND ⁽³⁾ values, nominal	0.4, 0.8, 1.0, 2.0, 3.0, 4.0 (Red Holders)

(1) Although the FSA-HP is designated for 1000nm -1100nm, the real spectral range is significantly wider and covers 500nm-1500nm range. However, the spec above refers only to designated wavelength and can't be guaranteed for out of the range wavelength. Red alignment laser can also be used with FSA-HP for alignment and targeting.

(2) 15 MW/cm² was maximal power density that was tested. Actual Maximum Power Density may be higher.

(3) ND bulk absorbing filters thermal lens threshold is 5W/cm² for beam size 5mm, 10W/cm² for 2mm beam and >30W/cm² for 1mm beam.

Check our website for latest version spec: www.ophiropt.com/laser-measurement

APPENDIX A: ND FILTERS

The ND filters provided with each FSA allow for final attenuation of the laser beam up to ND 6. Each filter in the holder provides for a different value of attenuation. To use, slide the desired holder into the slot in the FSA. A click is felt when the filter is properly aligned with the beam.

Holder Number	Filter A	Filter B
1	0.4	0.8
2	1	2
3	3	4 </td

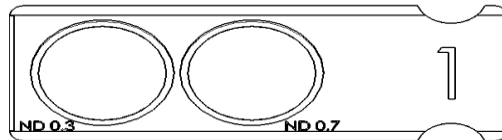

The attenuations at specified wavelengths are available in the charts below:

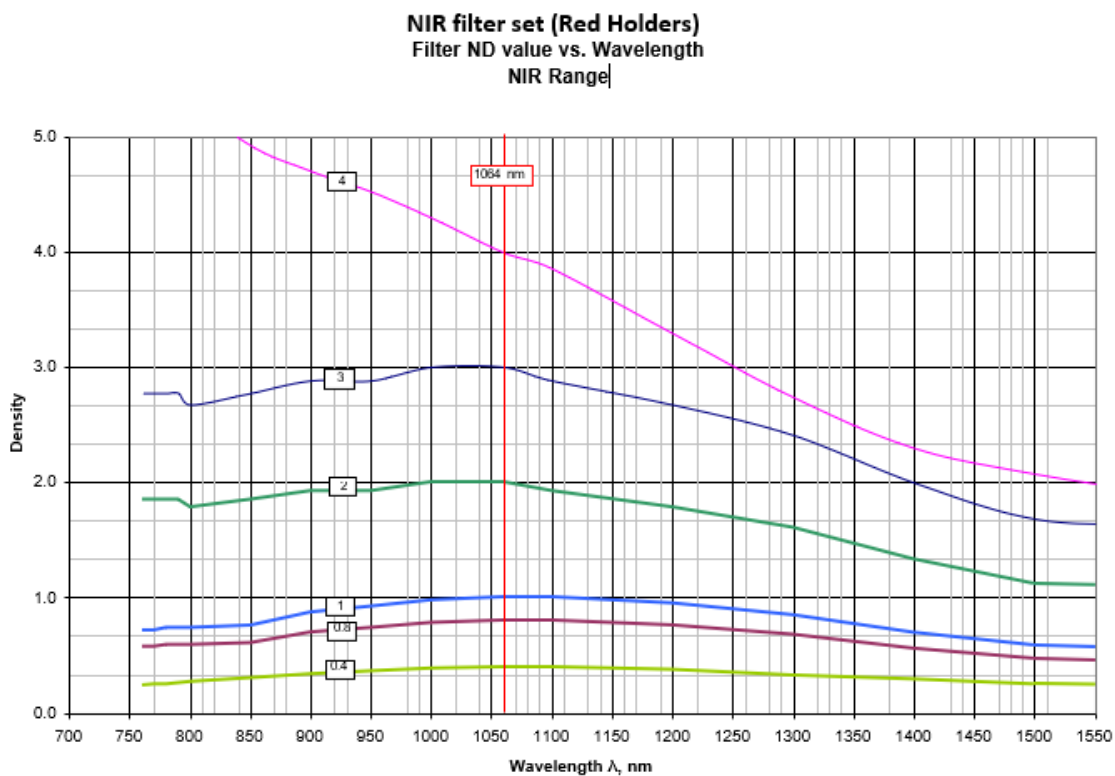

Copyright © 2022 by MKS Instruments, Inc.

All rights reserved. No part of this work may be reproduced or transmitted in any form or by any means, electronic or mechanical, including photocopying and recording, or by any information storage or retrieval system, except as may be expressly permitted in writing by MKS Instruments, Inc. mksinst™ is a trademark of MKS Instruments, Inc.

Document No 8J06009 Rev 01 10 March 2022

For latest version, please visit our website: www.ophiropt.com/photronics